

TOLLERANZE IN GRADO MEDIO COME DA NORMA: ISO2768-m

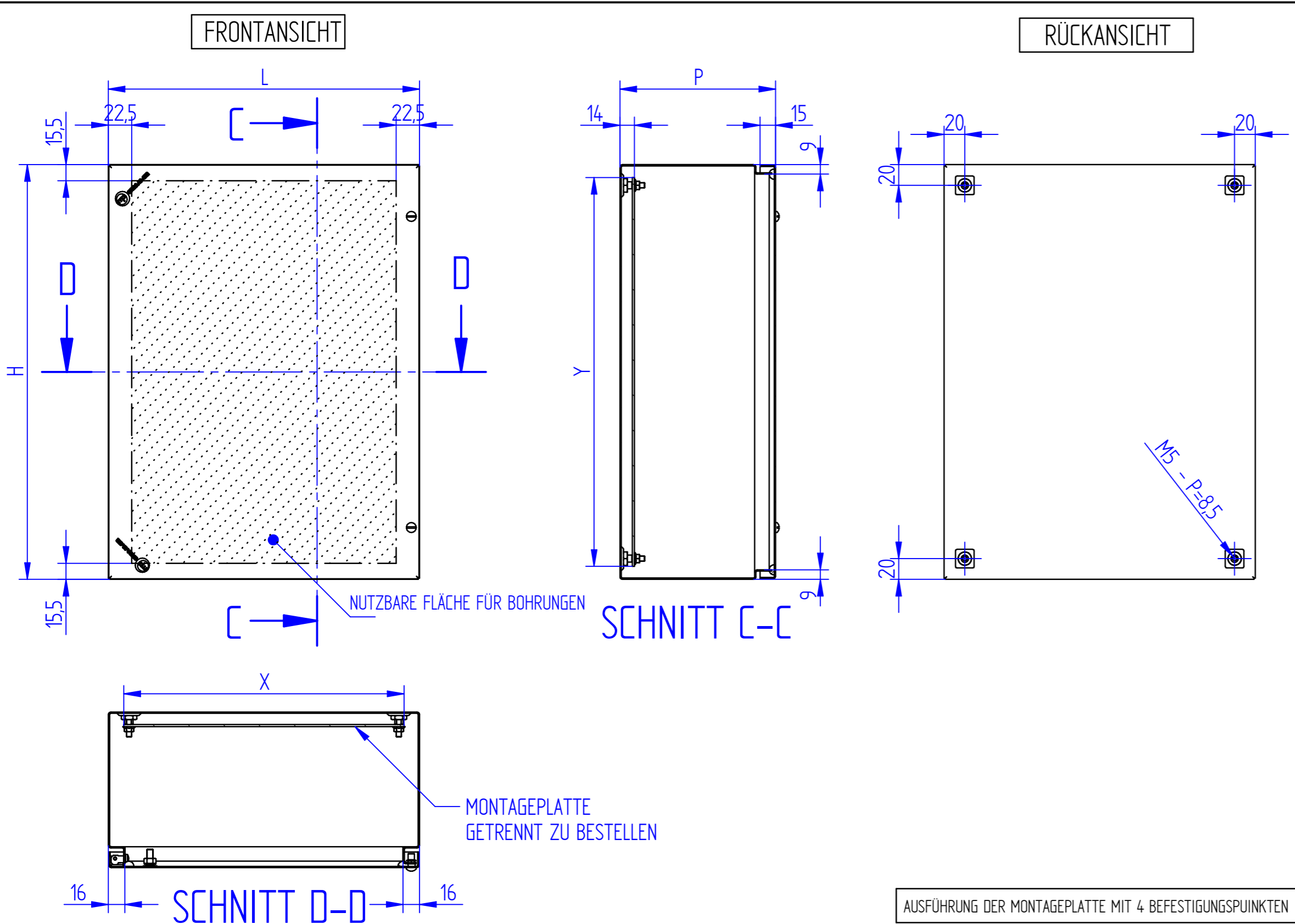
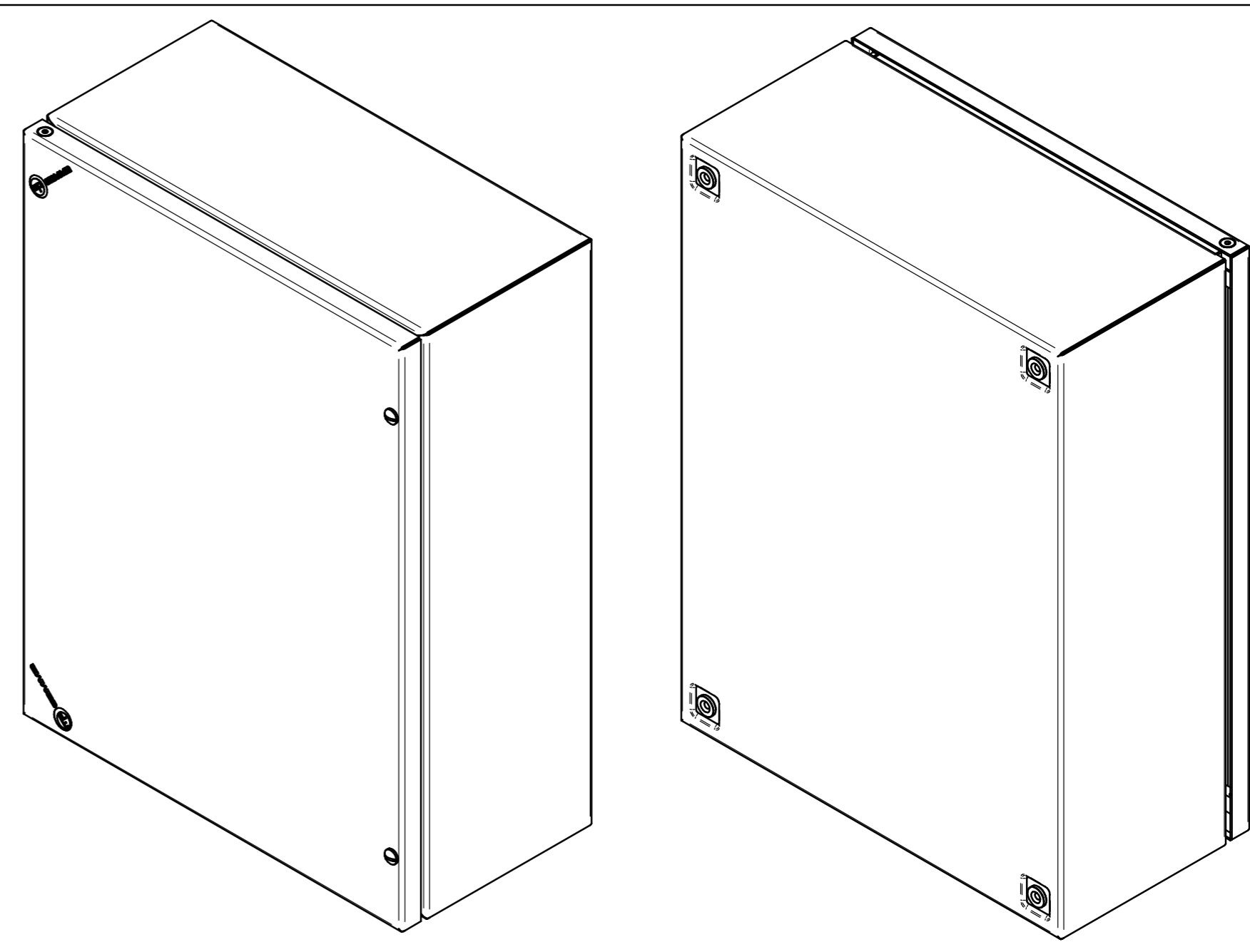
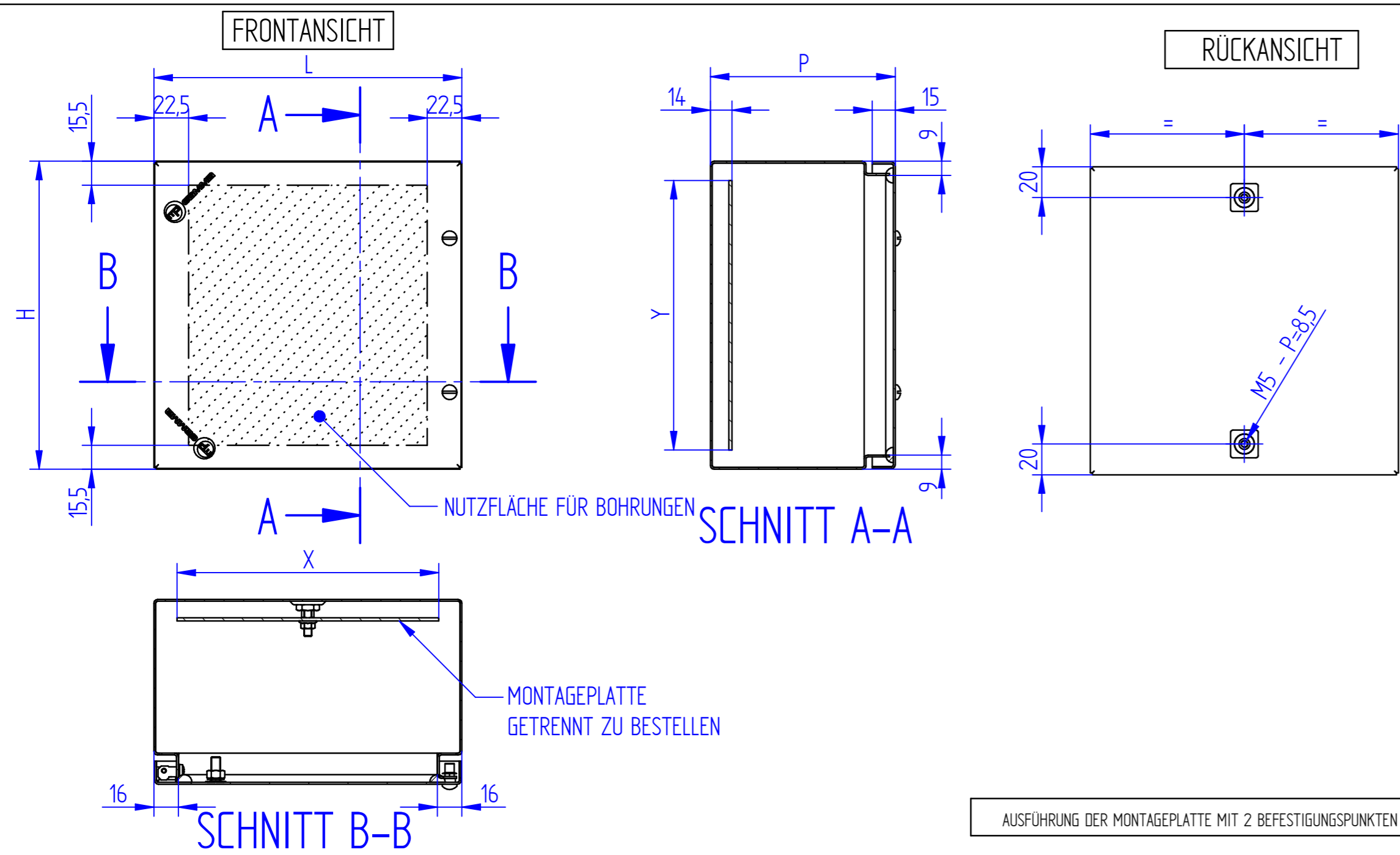

ARTIKEL CODE	ABMESSUNGEN			MONTAGEPLATTE			EIGENSCHAFTEN		
	B	H	T	CODE FÜR MONTAGEPLATTE	X	Y	NR. SCHLIES-SUNGEN	NR. BEFE-STIGUNGS-PUNKTE	NR. SCHARNIERE
CDN202012	200	200	120	PCDN2020	170	175	2	2	2
CDN203012	200	300	120	PCDN2030	170	275	2	2	2
CDN204012	200	400	120	PCDN2040	170	375	2	2	2
CDN252512	250	250	120	PCDN2525	220	225	2	4	2
CDN253012	250	300	120	PCDN2530	220	275	2	4	2
CDN254012	250	400	120	PCDN2540	220	375	2	4	2
CDN303015	300	300	150	PCDN3030	270	275	2	4	2
CDN304015	300	400	150	PCDN3040	270	375	2	4	2

STANDARD LAGE FÜR SCHARNIERE LINKE SEITE

Beschreibung		<p>DATENBLATT FÜR GEHÄUSE SERIE CDN</p>		
<p>Scheda Tecnica COD. SCTEC.CDN.IT</p>				